

P-3

Compact Microwave Energy Transmitter

[COMET]

2003/07/03

E.Fujiwara, Y.Takahashi, N.Tanaka, K.Saga, K.Tsujimoto (*1)
H.Matsumoto, K.Hashimoto, N.Shinohara, T.Mitani (*2)

(*1) : IHI Aerospace Co., Ltd.

(*2) : Radio Atmospheric Science Center [RASC], Kyoto University

IHI Aerospace has developed “Compact Microwave Energy Transmitter” with Kyoto University (RASC) for Space Solar Power Satellite/Station (SSPS) and Power Transmission system on the ground.

This transmitter is small, light, and high efficiency.



Feature

/ Small size : 310 × 99mm

/ Light weight : 7.1 kg

/ High efficiency : 25g/W

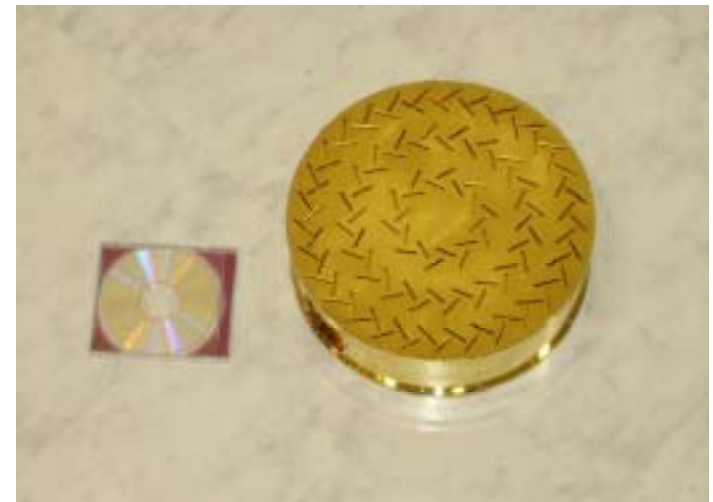

COMET

This Transmitter uses “Magnetron” to output high power , and has built-in “Phase-Locked Loop function” for stabilization of transmission frequency and phase.

Moreover, with injection locking function, this transmitter can be more stabilized.

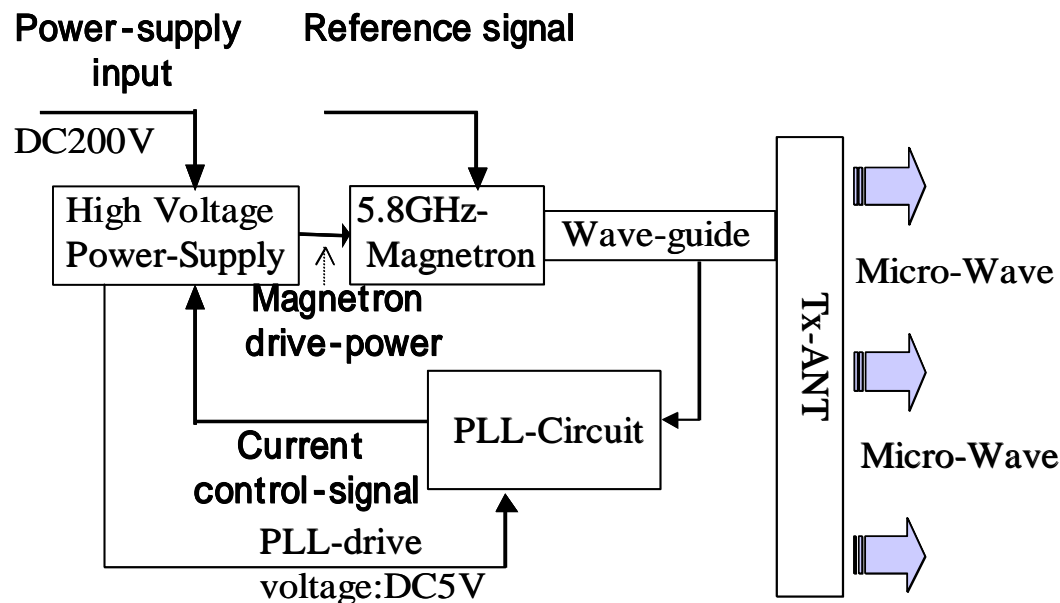

Block diagram

· Technology

⟨Very-thin structure⟩

/ Crossed-Slot connection Loss 0.1dB)

/ Thin RLSA (thickness 7mm)

* RLSA = Radial Line Slot Antenna

⟨Injection locking method⟩

/ 4-port directional coupler

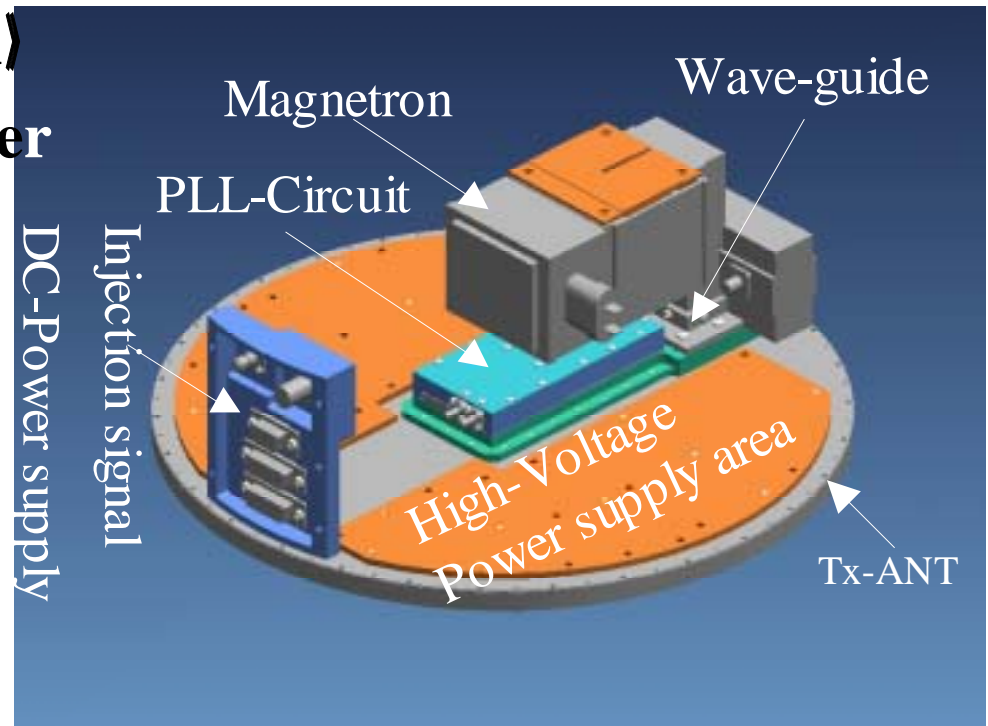

Inner structure

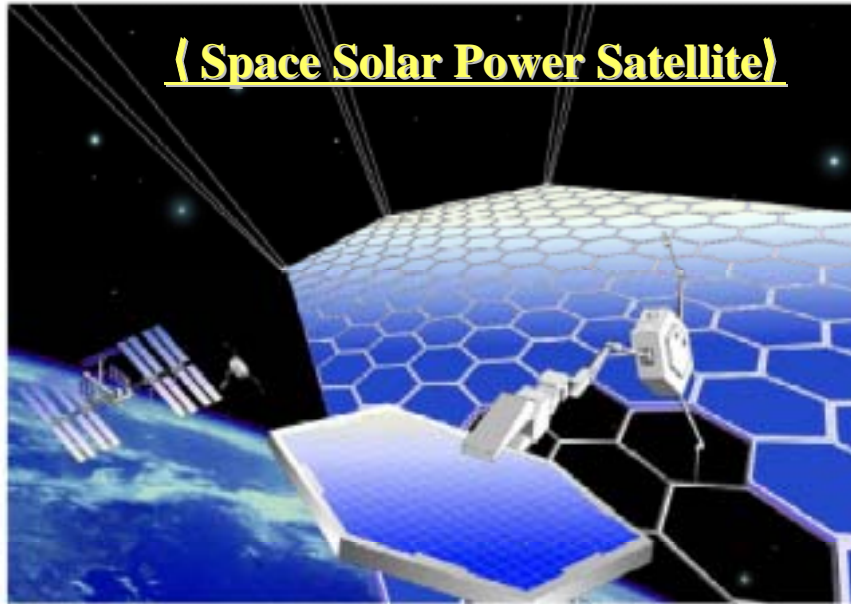

Courtesy of NASDA

山／孤島等
僻地観測点への電源供給

メリット:

- ・天候に関わらず電力供給
- ・緊急時のインフラ供給

